



Ball Valves PN 20/50 (Class 150/300) AIT & IIT Construction (Carbon Steel and Stainless Steel)



Fig. 315 / 330 Fig. 415 / 430

Manufacturing program:



Quality & Environmental Management:

Ball Valves PN 20/50 (Class 150/300)

DN 15 - 200 (½" – 8") PN 20 (Class 150)

DN 15 - 200 (½" – 8") PN 50 (Class 300)

Parts and materials

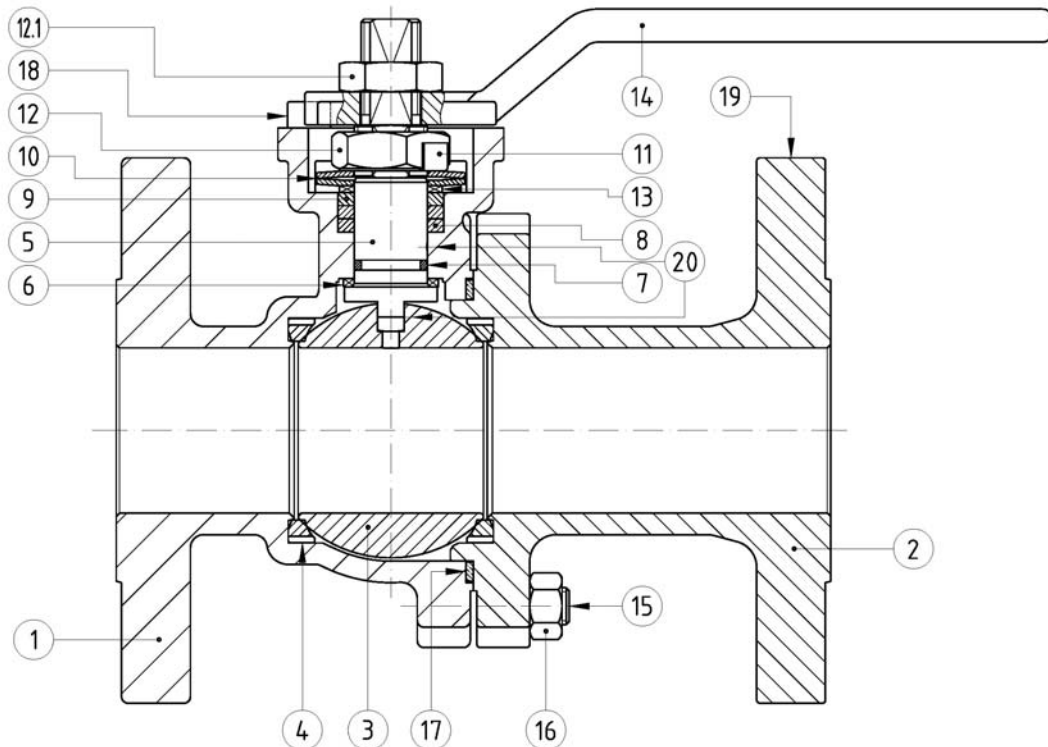

Item	Description	Material	
		AIT	IIT
1	Body	A 216 Gr. WCB (C ≤ 0,25)	A 351 Gr. CF8M
2	Body connector	A 216 Gr. WCB (C ≤ 0,25)	A 351 Gr. CF8M
3	Ball	A 351 Gr. CF8M (DN-15 ~ 25 A 479 Tp.316)	
4	Seat ring	PTFE	
5	Stem	A 479 Tp.316	
6	Stem thrust seal	25% G.F. PTFE	
7	"O" Ring	FKM	
8	Gland packing	Graphite	
9	Gland	AISI 303	
10	Disk spring	Inconel - 718	
11	Locking washer	AISI 304	
12	Gland nut	AISI 303	
12.1	Nut	AISI 303	
13	Antifriction washer	25% G.F. PTFE	
14	Wrench	A 216 Gr. WCB	
15	Stud	A 193 Gr. B7M	A 193 Gr. B8M
16	Nut	A 194 Gr. 2HM	A 194 Gr. 8M
17	Spiralwound gasket	AISI 316L + PTFE + Graphite	
18	Bolt	A2	
19	Identification plate	Stainless St.	
20	Antistatic Device	Stainless St.	



Ball Valves PN 20/50 (Class 150/300)

DN 15 - 200 (1/2" – 8") PN 20 (Class 150)

DN 15 - 200 (1/2" – 8") PN 50 (Class 300)

Dimensions

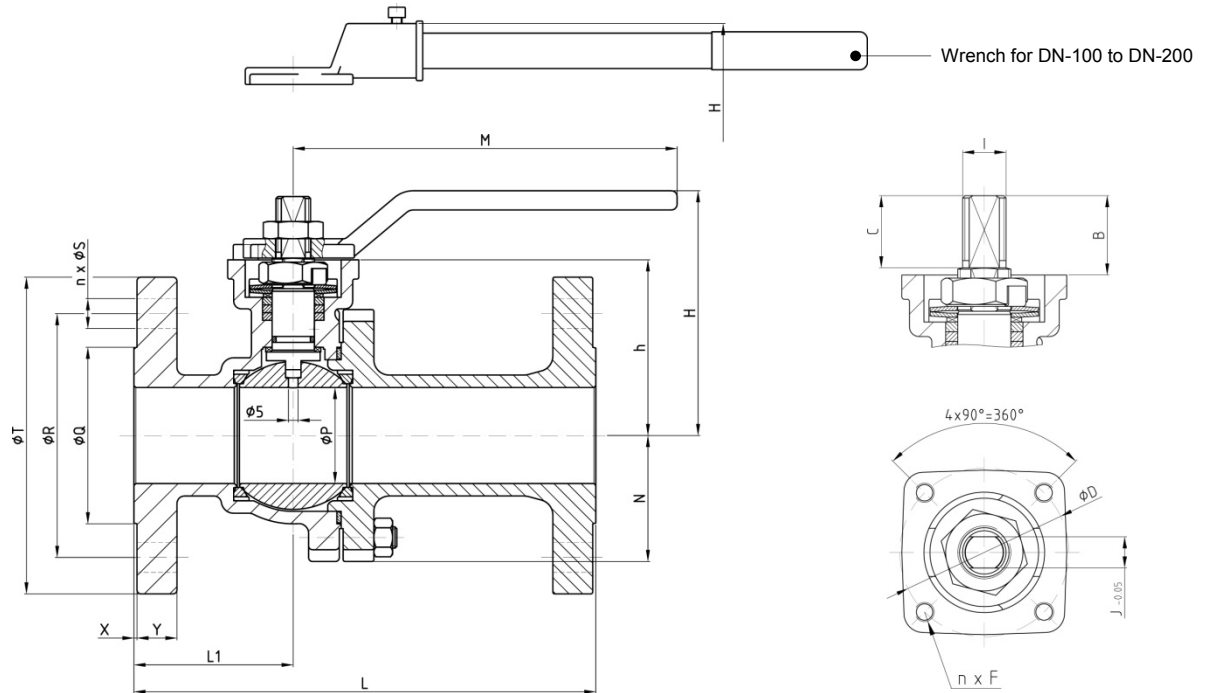

Series 315/415 (Class 150)

DN	ØP	L	L1	ØQ	ØR	n x ØS	ØT	X	Y	h	N	H	M	Weight
15 (1/2")	15	108	47	35	60,45	4 x 15,74	88,9	1,6	9,6	41	31	68	170	1,7
20 (3/4")	20	117	50	43	69,8	4 x 15,74	98,5	1,6	9,6	43	33	70	170	2,2
25 (1")	25	127	52	51	79,24	4 x 15,74	108	1,6	9,6	58,5	39	86	170	2,9
40 (1 1/2")	40	165	65	73	98,55	4 x 15,74	127	1,6	12,7	86,5	48	122,5	215	6
50 (2")	50	178	61	92	120,65	4 x 19	152	1,6	14,2	91,5	63	127,5	215	8,5
65 (2 1/2")	65	190	75	105	139,7	4 x 19	178	1,6	16	104	78	140	350	13,3
80 (3")	78	203	78,5	127	152,4	4 x 19	191	1,6	17,4	118,5	87	190	450	18,5
100 (4")	100	229	90	157	190,5	8 x 19	229	1,6	22,3	144	108	192,5	466	29,3
150 (6")	151	394	174	216	241,3	8 x 22,2	279,5	1,6	23,9	203	152	259	775	64,5
200 (8")	203	457	209	270	298,45	8 x 22,2	343	1,6	26,9	250	202	319	845	123,2

(*) Dimensions in mm

Series 330/430 (Class 300)

DN	ØP	L	L1	ØQ	ØR	n x ØS	ØT	X	Y	h	N	H	M	Weight
15 (1/2")	15	140	60	35	66,55	4 x 15,74	95	1,6	12,7	41	31	68	170	2,4
20 (3/4")	20	152	65	43	82,55	4 x 19	117,5	1,6	14,2	43	33	70	170	3,5
25 (1")	25	165	70	51	88,9	4 x 19	124	1,6	16	58,5	39	86	170	4,6
40 (1 1/2")	40	190	80	73	114,3	4 x 22,2	155,5	1,6	19	86,5	48	122,5	215	9,2
50 (2")	50	216	83	92	127	8 x 19	165	1,6	20,8	91,5	63	127,5	215	11,5
80 (3")	78	283	118	127	168,1	8 x 22,2	210	1,6	26,9	118,5	87	190	450	25
100 (4")	100	305	133	157	200,15	8 x 22,2	254	1,6	30,2	144	108	192,5	466	39,5
150 (6")	151	403	160	216	169,75	12 x 22,2	318	1,6	35	203	152	259	775	88,1
200 (8")	203	502	239	270	330,2	12 x 25,4	381	1,6	39,6	250	202	319	845	160,5

(*) Dimensions in mm

Actuator connection

DN	ISO 5211	B	C	ØD	n x F	I	J
15 (1/2")	F 05	18	11	50	4 x M6	M10	7
20 (3/4")	F 05	18	11	50	4 x M6	M10	7
25 (1")	F 05	22	21	50	4 x M6	M12	8
40 (1 1/2")	F 07	33	32	70	4 x M8	M18	12
50 (2")	F 07	33	32	70	4 x M8	M18	12
65 (2 1/2")	F 07	34	33	70	4 x M8	M22	15
80 (3")	F 10	34	33	102	4 x M10	M22	15
100 (4")	F 10	45	43,5	102	4 x M10	M28	19
150 (6")	F 12	56	54,5	125	4 x M12	M36	24
200 (8")	F 14	69	67	140	4 x M16	M48	32

(*) Dimensions in mm

ICP VALVES S.A.

E-Mail: sales@icp-valves.com

Internet: www.icp-valves.com

Authorized Distributor

SERIES
SFF



Ball Valves PN 20/50 (Class 150/300)

DN 15 - 200 (1/2" – 8") PN 20 (Class 150)

DN 15 - 200 (1/2" – 8") PN 50 (Class 300)

General Characteristics, Torque & KV, P&T Rating

GENERAL CHARACTERISTICS	Fig.LCV Series SFF	Split Body	Floating Ball	Full Bore
DESIGN STANDARDS				
Valves design	ISO 17292	ASME B16.34	EN 1983	
Body design	ISO 17292			
Shell thickness	ASME B16.34			
Flanges	ASME B16.5 Raised face			
Face to face dimensions	ASME B16.10 Long pattern	EN 558-2 Series 3, 4 & 12		
Actuator mounting flange	ISO 5211	EN 15081		
Wetted parts materials and bolting	NACE MR.01.75			
Shell finishing quality	MSS SP 55			
Marking	ISO 17292	CE - PED	EN 19	
TESTS AND CERTIFICATES				
Quality Assurance	ISO 9001	CE - PED		
Fire Safe certification	ISO 10497: 2004			
Pressure testing	API 598	EN 12266		
Other	ISO 14001	ATEX		

Torque Values in Nm

VALVE SIZE	AT DIFFERENTIAL PRESSURE		VALVE SIZE	AT DIFFERENTIAL PRESSURE	
	Class 150	Class 300		Class 150	Class 300
	20 bar	50 bar		20 bar	50 bar
DN 15 (1/2")	6	10	DN 65 (2.1/2")	50	
DN 20 (3/4")	8	13	DN 80 (3")	79	135
DN 25 (1")	12	17	DN 100 (4")	130	170
DN 40 (1.1/2")	22	30	DN 150 (6")	220	308
DN 50 (2")	36	49	DN 200 (8")	630	780

Kv Values in m³/h

DN 15 (1/2")	DN 20 (3/4")	DN 25 (1")	DN 40 (1 1/2")	DN 50 (2")
20	40	75	170	270
DN 65 (2 1/2")	DN 80 (3")	DN 100 (4")	DN 150 (6")	DN 200 (8")
550	1000	1650	4200	9000

Pressure-Temperature

For A216 Gr. WCB only. For other materials consult ASME B16.34

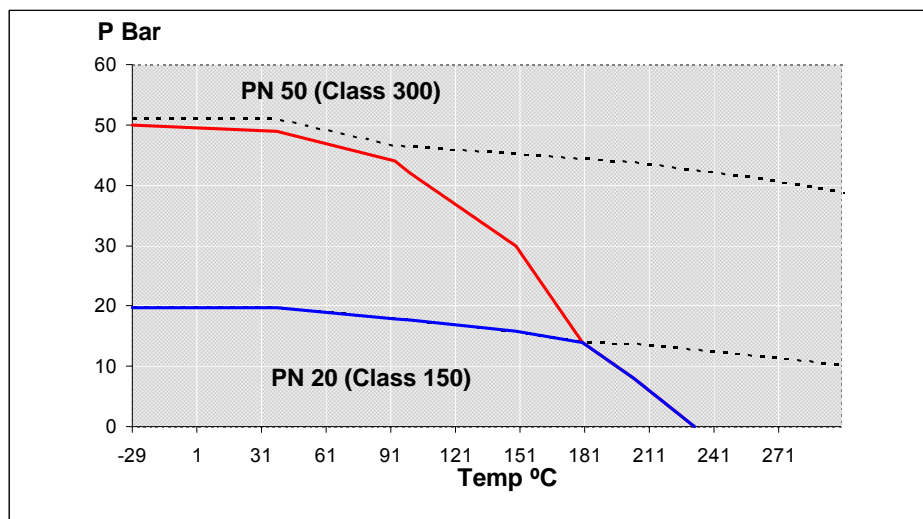

PTFE SEATS



Ball Valves PN 20/50 (Class 150/300)

DN 15 - 200 (1/2" – 8") PN 20 (Class 150)

DN 15 - 200 (1/2" – 8") PN 50 (Class 300)

General Characteristics, Torque & KV, P&T Rating

Pressure-Temperature

For A351 Gr. CF8M only. For other materials consult ASME B16.34

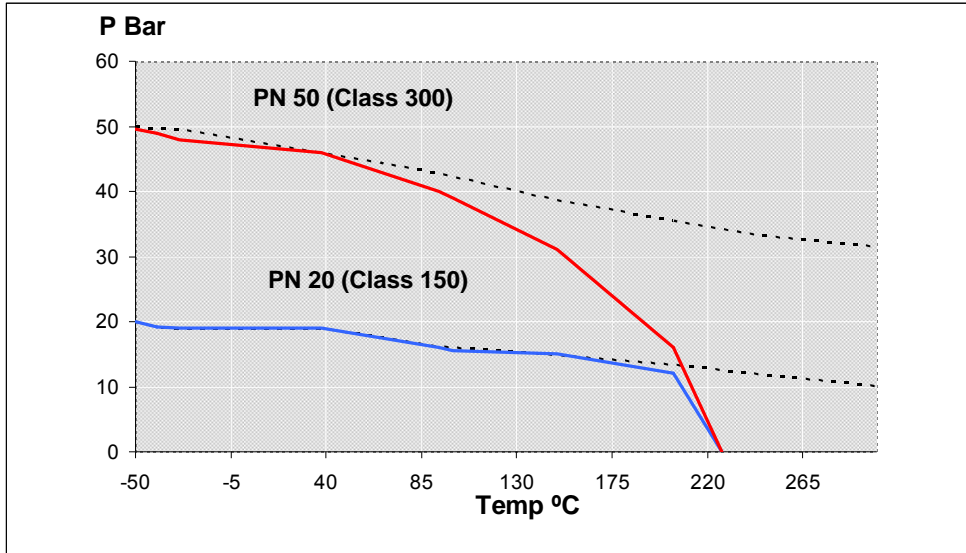

PTFE SEATS