



Forged Globe Valves
Fig. G800 Class 800
Size ½" – 2" (DN 15 – 50)



FIG. G800

GLOBE VALVE

BS 5352, ASME B16.34
Connections according to:
ANSI B 1.20.1 (NPT)
ANSI B 16.11 (SW)
CE

Forged Globe Valves

Fig. G800 Class 800

Parts and Materials

Parts and materials

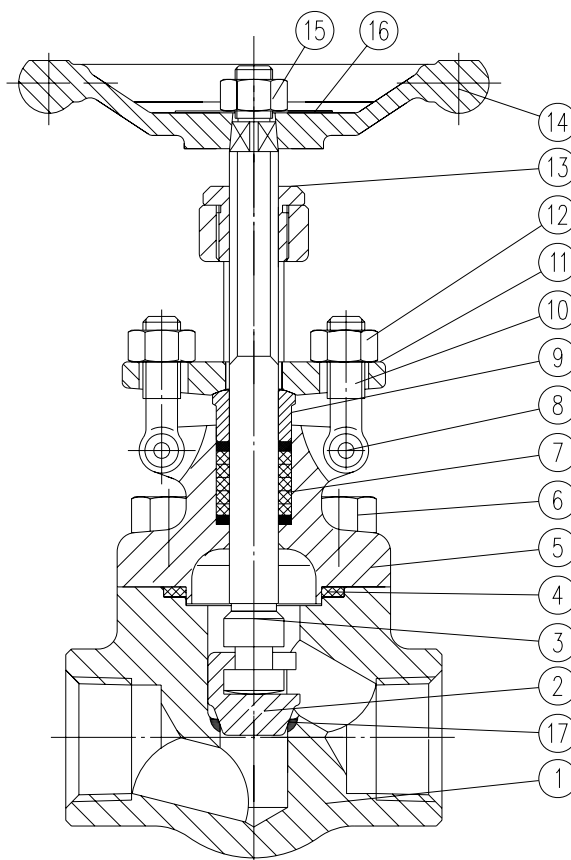

Item	Description	Material	
		Carbon Steel	Stainless Steel
1	Body	A 105	A 182 F316L
2	Disc	AISI 420 + STL	A 182 F316L
3	Stem	AISI 410	A 182 F316L
4	Gasket	AISI 304 + Graphite	AISI 316 + Graphite
5	Bonnet	A 105	A 182 F316L
6	Bolt	A 193 B7	A 193 B8M
7	Packing	Flexible Graphite + Carbon Fibre	
8	Pin	AISI 420	AISI 304
9	Packing Gland	AISI 420	AISI 316L
10	Eye Bolt	A 193 B8	A 193 B8M
11	Gland Flange	A 105	A 182 F316L
12	Hex Nut	A 194 8	A 194 8M
13	Yoke Nut	AISI 410	
14	Handw heel	A 197	
15	Hex Nut	1035 Zinc Plated	
16	Nameplate	Aluminium	
17	Seat	A 105 + STL	A 182 F316L + STL

Forged Globe Valves

Fig. G800 Class 800

Dimensions

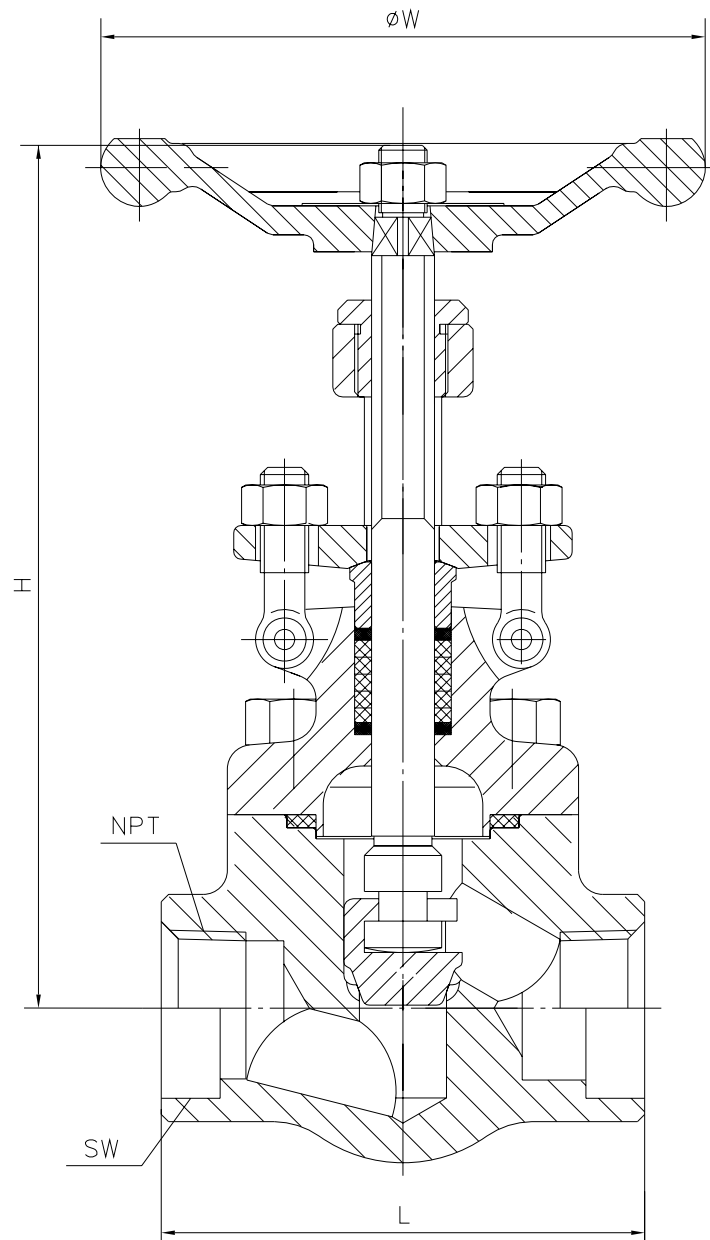

Dimensions

SIZE	L	NPT	ϕW	H	Weight
1/2" (DN 15)	79	1/2"	100	158	2,2
3/4" (DN 20)	92	3/4"	100	163	2,4
1" (DN 25)	110	1"	125	193	4,2
1 1/4" (DN 32)	152	1 1/4"	160	250	6
1 1/2" (DN 40)	152	1 1/2"	160	250	8
2" (DN 50)	172	2"	180	291	12,8

(*) Dimensions in mm and weight in kg.

Note:

Dimensions not subject to International Standards can vary in $\pm 10\%$. ICP reserves the right to change those dimensions without notice, due to they do not affect integrity and performance of the valves.



Forged Globe Valves

Fig. G800 Class 800

General Characteristics, Torque, Kv, P&T Rating

GENERAL CHARACTERISTICS	Forged Globe Valve		
DESIGN STANDARDS			
Valves design	BS 5352	ASME B16.34	
Connections	ANSI B 1.20.1	ANSI B 16.11	
Face to face dimensions	Manufacturer's standard		
TESTS AND CERTIFICATES	API 598		
Quality Assurance	ISO 9001		
Pressure testing	EN 12266-1		
Marking	EN 19		

Kv Values in m3/h

VALVE SIZE	Kv	VALVE SIZE	Kv
½" (DN 15)	1	1¼" (DN 32)	9,5
¾" (DN 20)	2,3	1½" (DN 40)	15
1" (DN 25)	4,6	2" (DN 50)	19,9

Pressure-Temperature

ASTM A105

